



# SHENZHEN AGLARE LIGHTING CO., LTD.

Tel: +86-755-88868631 FAX: +86-755-88863251 E-mail: [Aglare@aglare.cn](mailto:Aglare@aglare.cn) Website: <http://www.aglare.cn>  
Add: Factory A, Supply and Marketing Cooperative Park Guanlan Avenue, Guanlan Town Bao'an District, Shenzhen City, Guangdong, China

## Specification for Approval

Customer: \_\_\_\_\_

Product: YJ-DL265R30X1W

Part No.: \_\_\_\_\_

Ref. No: \_\_\_\_\_

Date: 2010-06-30

### Made by Shenzhen Aglare Lighting Co. Ltd

Production Dept	Q.C. Dept	Engineering Dept	Marketing Dept
Wen Liu	Fang Yang	Jiang Yang	Fang Wang

### Approved by

Engineering Dept	Production Dept	Q.C. Dept	Manager



# SHENZHEN AGLARE LIGHTING CO., LTD.

Tel: +86-755-88868631

FAX: +86-755-88863251

E-mail: [Aglare@aglare.cn](mailto:Aglare@aglare.cn)

Website: <http://www.aglare.cn>

Add: Factory A, Supply and Marketing Cooperative Park Guanlan Avenue, Guanlan Town Bao'an District, Shenzhen City, Guangdong, China

## 1.Features:

1. Ceiling Light
2. LED quantity: 1 pieces
3. LED type: 30w high power led
4. Operating condition: 960mA
5. Input voltage: AC 85-260V
6. Total power consumption: 30W
7. Colors available: red, green, blue, yellow, white, warm white
8. Lifespan: 30,000 hours
9. Net weight: 1650 g
10. Maximum size: 265\*2265\*110 mm
11. Viewing angle: 130°

Picture:

## 2.Application Case:





# SHENZHEN AGLARE LIGHTING CO., LTD.

Tel: +86-755-88868631

FAX: +86-755-88863251

E-mail: [Aglare@aglare.cn](mailto:Aglare@aglare.cn)

Website: <http://www.aglare.cn>

Add: Factory A, Supply and Marketing Cooperative Park Guanlan Avenue, Guanlan Town Bao'an District, Shenzhen City, Guangdong, China



### 3.Package Dimensions (mm):

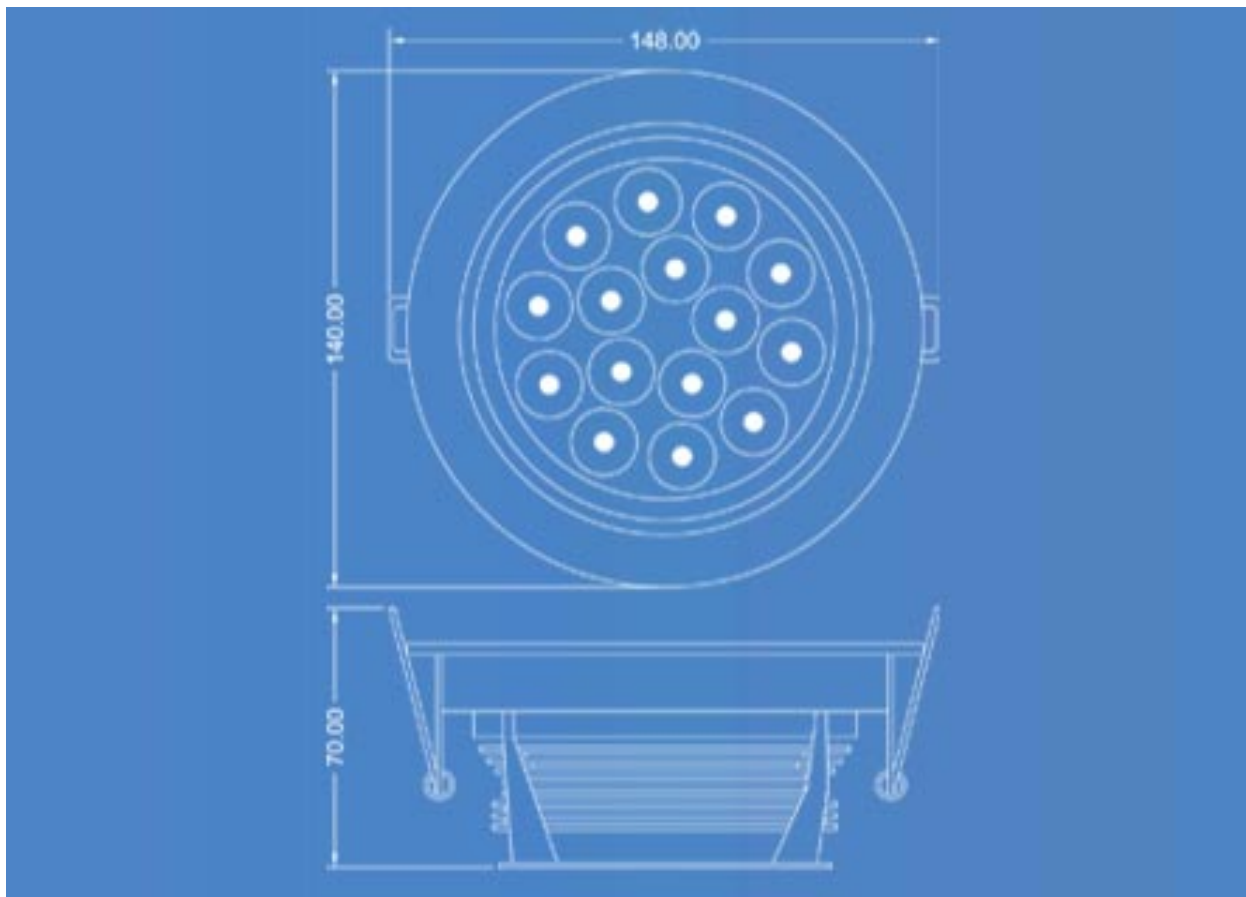



# SHENZHEN AGLARE LIGHTING CO., LTD.

Tel: +86-755-88868631

FAX: +86-755-88863251

E-mail: [Aglare@aglare.cn](mailto:Aglare@aglare.cn)

Website: <http://www.aglare.cn>

Add: Factory A, Supply and Marketing Cooperative Park Guanlan Avenue, Guanlan Town Bao'an District, Shenzhen City, Guangdong, China

## 4. Absolute Maximum Rating at TA=25°C:

Part Number	Emitting Color	Input Voltage	Wattage	Waterproof Degree	LED Quantity	Luminous Intensity(Lm)		Net Weight (g)
						MIN	MAX	
YJ-DL265R30X1R	Red	AC90-2 40V	30W	/	1pcs	1320	1560	1650g
YJ-DL265R30X1G	Green		30W	/	1pcs	1320	1560	1650g
YJ-DL265R30X1B	Blue		30W	/	1pcs	336	432	1650g
YJ-DL265R30X1Y	Yellow		30W	/	1pcs	1320	1440	1650g
YJ-DL265R30X1W	Pure White		30W	/	1pcs	1680	2400	1650g
YJ-DL265R30X1WW	Warm White		30W	/	1pcs	1560	2160	1650g

## 5. Characteristic:

Electro-Optical characteristics ( Pure White )						( Ta=25°C )	
Parameter	Test Condition	Symbol	Value			Unit	
			Min	Typ	Max		
Color temperature	If=960mA	peak	5000		6500	k	
Forward voltage	If=960mA	VF	3.2		3.8	V	
Power consumption	If=960mA	P	28	30	32	W	
Luminous intensity	If=960mA	Iv	1680	2000	2400	LM	
Reverse current	VF=5V	IR	--	--	5	UA	
Useful life	If =960mA		30000		50000	H	

## 6. Lumen Decrease

Operating time ( hours )	Lumen decrease [ % ]
1000	8
5000	15
10000	20



# SHENZHEN AGLARE LIGHTING CO., LTD.

Tel: +86-755-88868631

FAX: +86-755-88863251

E-mail: [Aglare@aglare.cn](mailto:Aglare@aglare.cn)

Website: <http://www.aglare.cn>

Add: Factory A, Supply and Marketing Cooperative Park Guanlan Avenue, Guanlan Town Bao'an District, Shenzhen City, Guangdong, China

## 7.Package Information:

Net (g)	Gross (kg)	Carton1 Size (CM)	Carton2 Size (CM)	Q'ty/Carton 1
1650	14.2	29.5*29.5*11.5	59.5*59.5*23.5	8

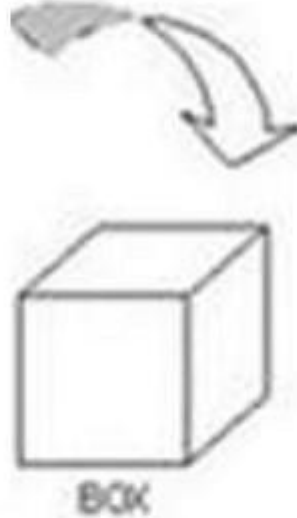
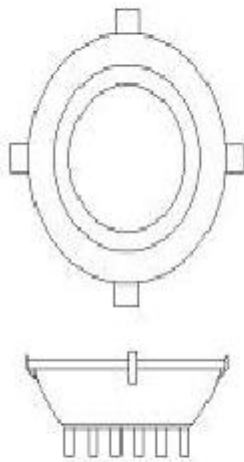

## 9.After-sales service

All products are guaranteed to use in one year. Under the right and normal using condition, quality warranty is based on correct conservation, assemblage, and maintenance. As incorrect usage, and disobeying product operation, it's not guaranteed. To the problem within promised time, "Aglare" will solve it by repair, substitute accessories or replacement for your option. Upon exceeding the promised time, there will be material and maintenance fees to be paid by c

TEL: +86-755-88868631

FAX: +86-755-88863251

E-mail: [service@aglare.cn](mailto:service@aglare.cn)