



SHENZHEN AGLARE LIGHTING CO., LTD.

Tel: +86-755-88868631

FAX: +86-755-88863251

E-mail: Aglare@aglare.cn

Website: <http://www.aglare.cn>

Add: Factory A, Supply and Marketing Cooperative Park Guanlan Avenue, Guanlan Town Bao'an District, Shenzhen City, Guangdong, China

Specification for Approval

Customer: _____

Product: YJ-DL148R9X1W-B

Part No.: _____

Ref. No: _____

Date: 2010-06-24

Made by Shenzhen Aglare Lighting Co. Ltd

Production Dept	Q.C. Dept	Engineering Dept	Marketing Dept
Wen Liu	Fang Yang	Jiang Yang	Fang Wang

Approved by

Engineering Dept	Production Dept	Q.C. Dept	Manager



SHENZHEN AGLARE LIGHTING CO., LTD.

Tel: +86-755-88868631

FAX: +86-755-88863251

E-mail: Aglare@aglare.cn

Website: <http://www.aglare.cn>

Add: Factory A, Supply and Marketing Cooperative Park Guanlan Avenue, Guanlan Town Bao'an District, Shenzhen City, Guangdong, China

1.Features:

1. Ceiling Light
2. LED quantity: 9 pieces
3. LED type: 1w high power led
4. Operating condition: 350mA
5. Input voltage: AC 85-260V
6. Total power consumption: 9W
7. Colors available: red, green, blue, yellow, white, warm white
8. Luminous intensity: R (495-585lm), G (495-585lm), B (126-162lm), Y (495-540lm), W (630-900lm), WW (585-810lm)
9. Brightness: 1m (2300lux), 2m (650lux), 3m (430lux)
10. Lifespan: 30,000 hours
11. Net weight: 605g
12. Maximum size: 148*148*58 mm³
13. Viewing angle: 15 to 80° (selectable)

Picture:



2.Application Case:





SHENZHEN AGLARE LIGHTING CO., LTD.

Tel: +86-755-88868631

FAX: +86-755-88863251

E-mail: Aglare@aglare.cn

Website: <http://www.aglare.cn>

Add: Factory A, Supply and Marketing Cooperative Park Guanlan Avenue, Guanlan Town Bao'an District, Shenzhen City, Guangdong, China



3.Package Dimensions (mm):

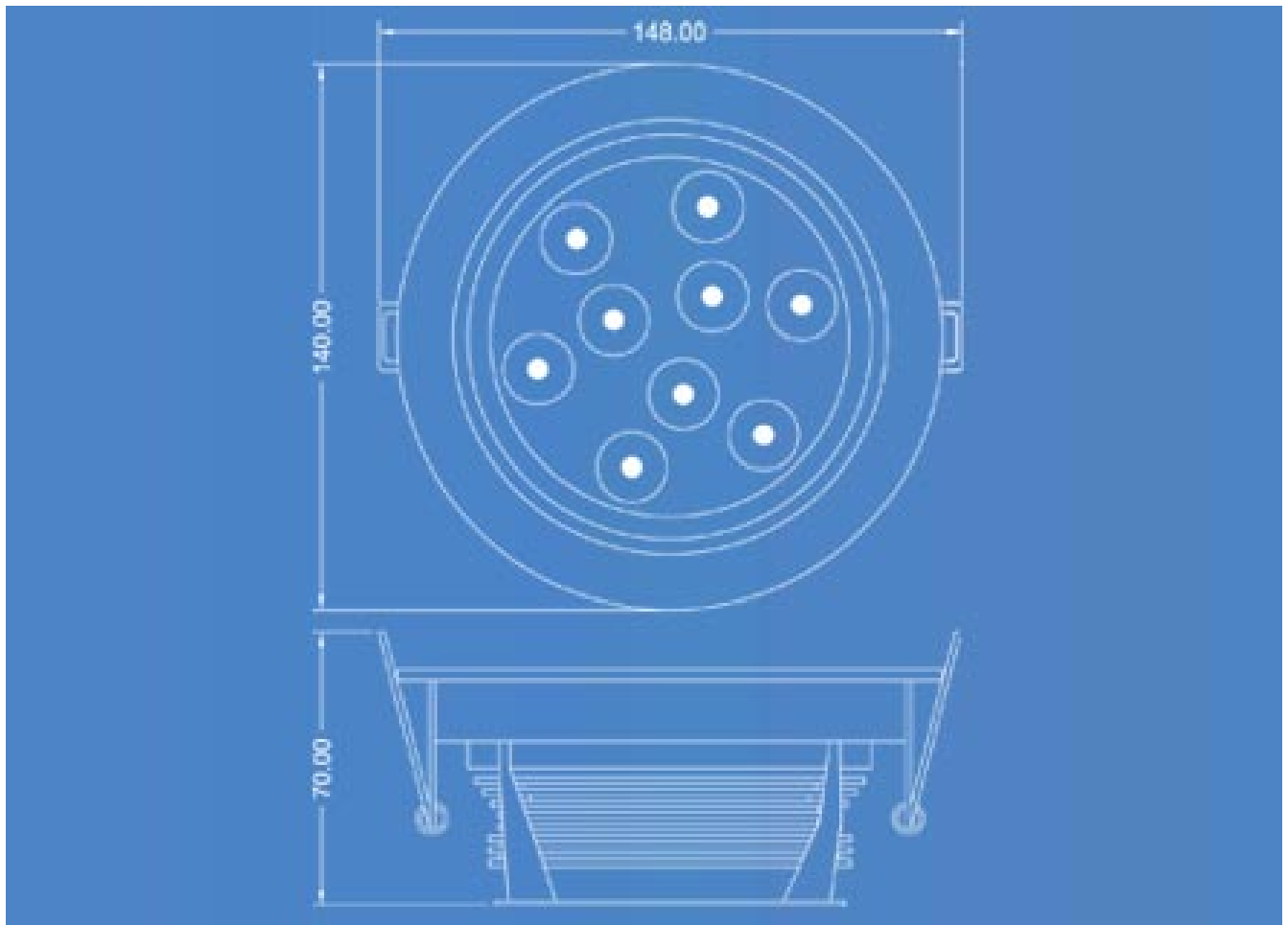



SHENZHEN AGLARE LIGHTING CO., LTD.

Tel: +86-755-88868631

FAX: +86-755-88863251

E-mail: Aglare@aglare.cn

Website: <http://www.aglare.cn>

Add: Factory A, Supply and Marketing Cooperative Park Guanlan Avenue, Guanlan Town Bao'an District, Shenzhen City, Guangdong, China

4. Absolute Maximum Rating at TA=25°C:

Part Number	Emitting Color	Input Voltage	Wattage	Waterproof Degree	LED Quantity	Luminous Intensity(Lm)		Net Weight (g)
						MIN	MAX	
YJ-DL148R9X1R-B	Red	AC85V-A C260	9W	/	9pcs	495	585	605
YJ-DL148R9X1G-B	Green		9W	/	9pcs	495	585	605
YJ-DL148R9X1B-B	Blue		9W	/	9pcs	126	162	605
YJ-DL148R9X1Y-B	Yellow		9W	/	9pcs	495	540	605
YJ-DL148R9X1W-B	Pure White		9W	/	9pcs	630	900	605
YJ-DL148R9X1WW-B	Warm White		9W	/	9pcs	585	810	605

5. Characteristic:

Electro-Optical characteristics (Pure White)						(Ta=25°C)	
Parameter	Test Condition	Symbol	Value			Unit	
			Min	Typ	Max		
Color temperature	If=350mA		5000		6500	K	
Forward voltage	If=350mA	VF	3.2		3.8	V	
Power consumption	If=350mA	P	8	9	10	W	
Luminous intensity	If=350mA	Iv	630	750	900	LM	
Reverse current	VF=5V	IR	--	--	5	UA	
Useful life	IF=350mA		30000		50000	H	

6. Lumen Decrease

Operating time (hours)	Lumen decrease [%]
1000	8
5000	15
10000	20



SHENZHEN AGLARE LIGHTING CO., LTD.

Tel: +86-755-88868631 FAX: +86-755-88863251 E-mail: Aglare@aglare.cn Website: <http://www.aglare.cn>
Add: Factory A, Supply and Marketing Cooperative Park Guanlan Avenue, Guanlan Town Bao'an District, Shenzhen City, Guangdong, China

7. Average illuminance figure

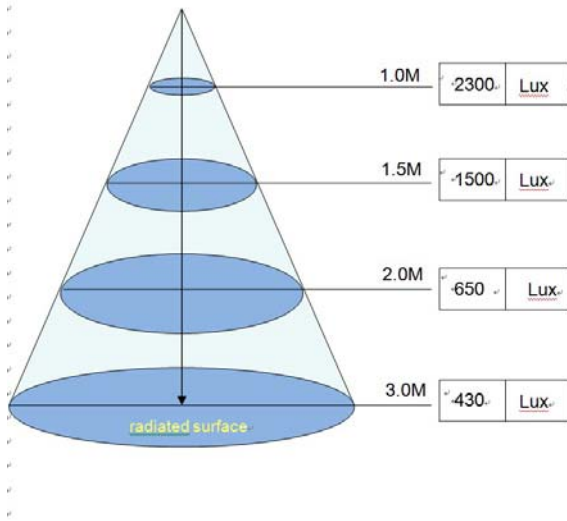

8. Package Information:

Net (g)	Gross (kg)	Carton1 Size (CM)	Quantity	Carton2 Size (CM)	Q'ty/Carton 1
605	11.7	30*30*7.7	4	60*30*16	16

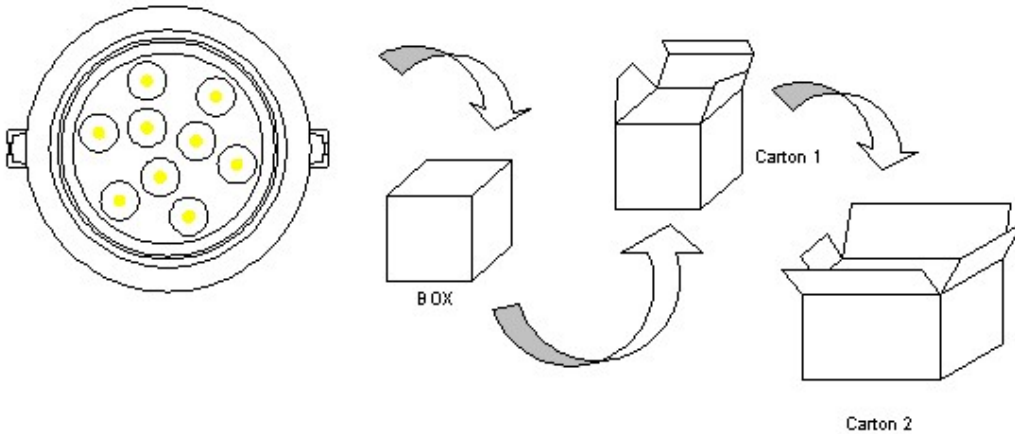

9. After-sales service

All products are guaranteed to use in one year. Under the right and normal using condition, quality warranty is based on correct conservation, assemblage, and maintenance. As incorrect usage, and disobeying product operation, it's not guaranteed. To the problem within promised time, "Aglare" will solve it by repair, substitute accessories or replacement for your option. Upon exceeding the promised time, there will be material and maintenance fees to be paid by c